

1 | 2 | 3 | 4

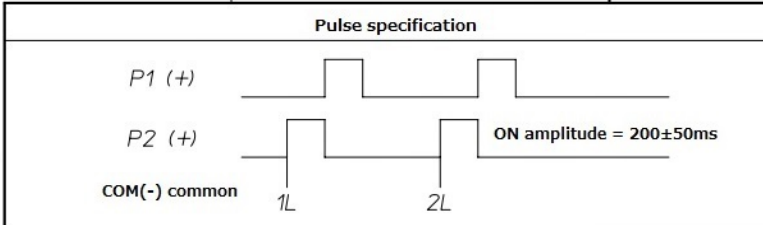

microcomputer meter		
Type	SK25MT1SNL	
Qmax.	m <sup>3</sup> /h	2.5
Normal working pressure	kPa	2.8±0.5
Pmax.	kPa	10
Max. indicating Vol.	m <sup>3</sup>	9999
Min. indicating Vol.	L	0.2
Cyclic volume	L/rev.	0.5
Connection pipe	15A/20A	
Connection screw	M36x2	
Weight	kg	2.0

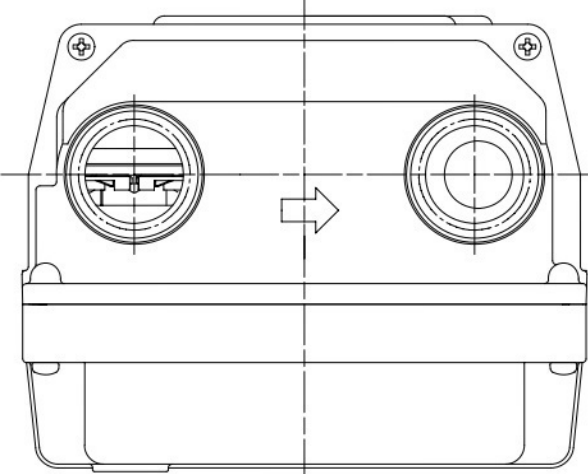

Specification Classification	Name tag
standard specification	007
Simplified gas specification	008
Housing complex specifications	009
Agricultural A Specification	037

Legal Replacement Date Label

Producer's mark (example)

LIA No. 2 inspection certificate attached

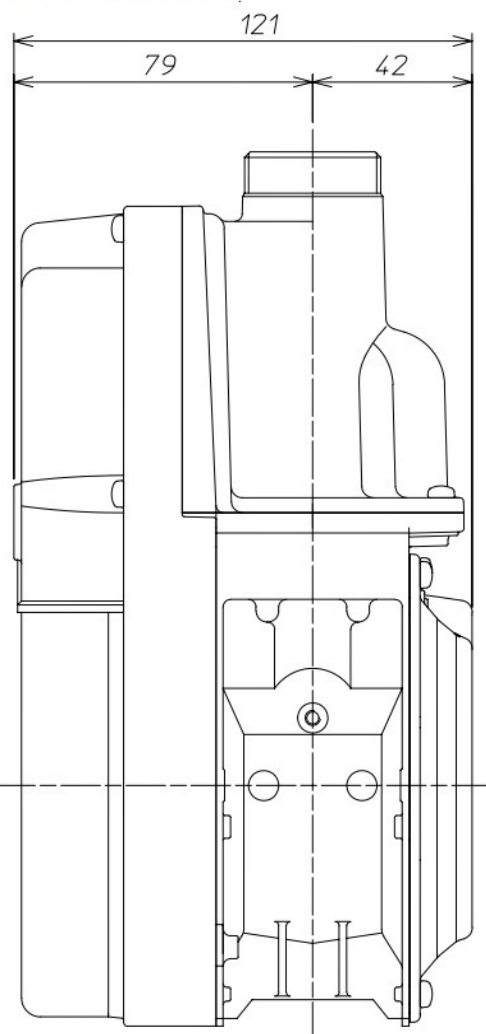
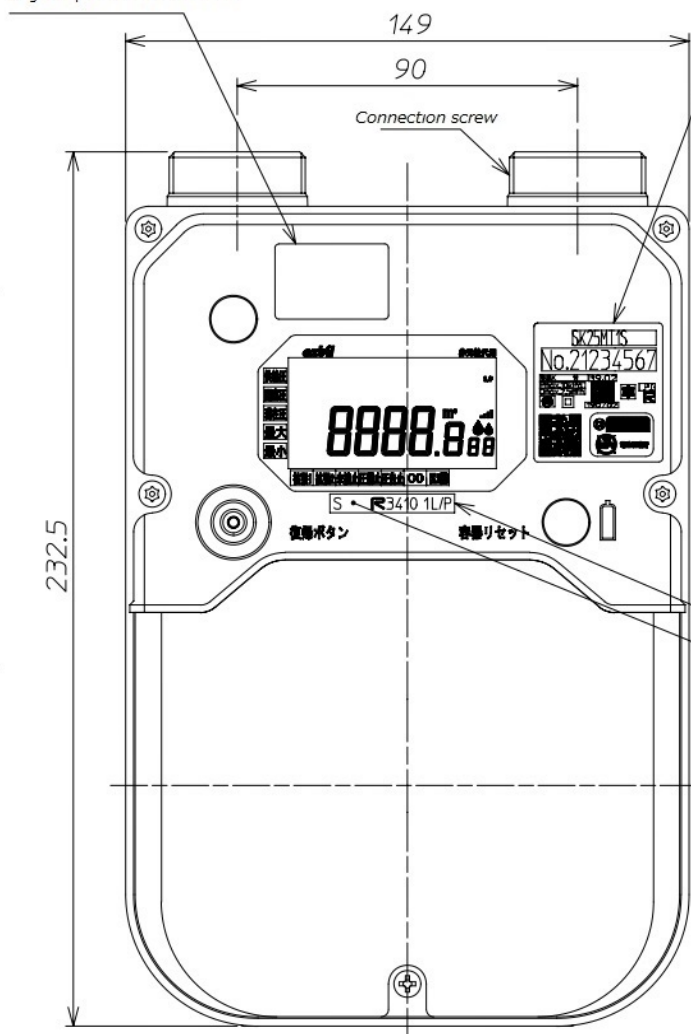

3			MATERIAL		REMARK	
2						
1			PROJECTION		SCALE	
MARK	COUNT	DATE	REVISION		1:2	NAME
APPROVED	CHECKED	DRAWN	DATE	Azbil Kimmon Co.,Ltd. JAPAN		DRAWING No.
Ishiseki	t.suzuki	Shimizu	2017.7.7			Z-KSMA25-A100A

1 | 2 | 3 | 4