

1

2

3

4

A

A

B

B

C

C

D

D

E

E

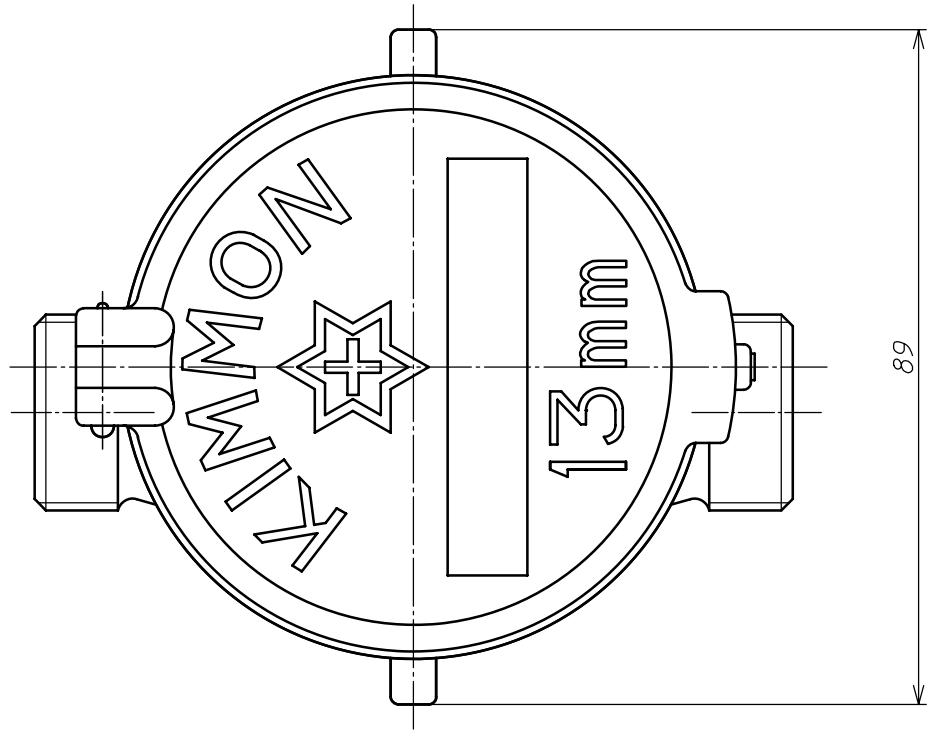

26.441 Dia.
14 Thread/inch

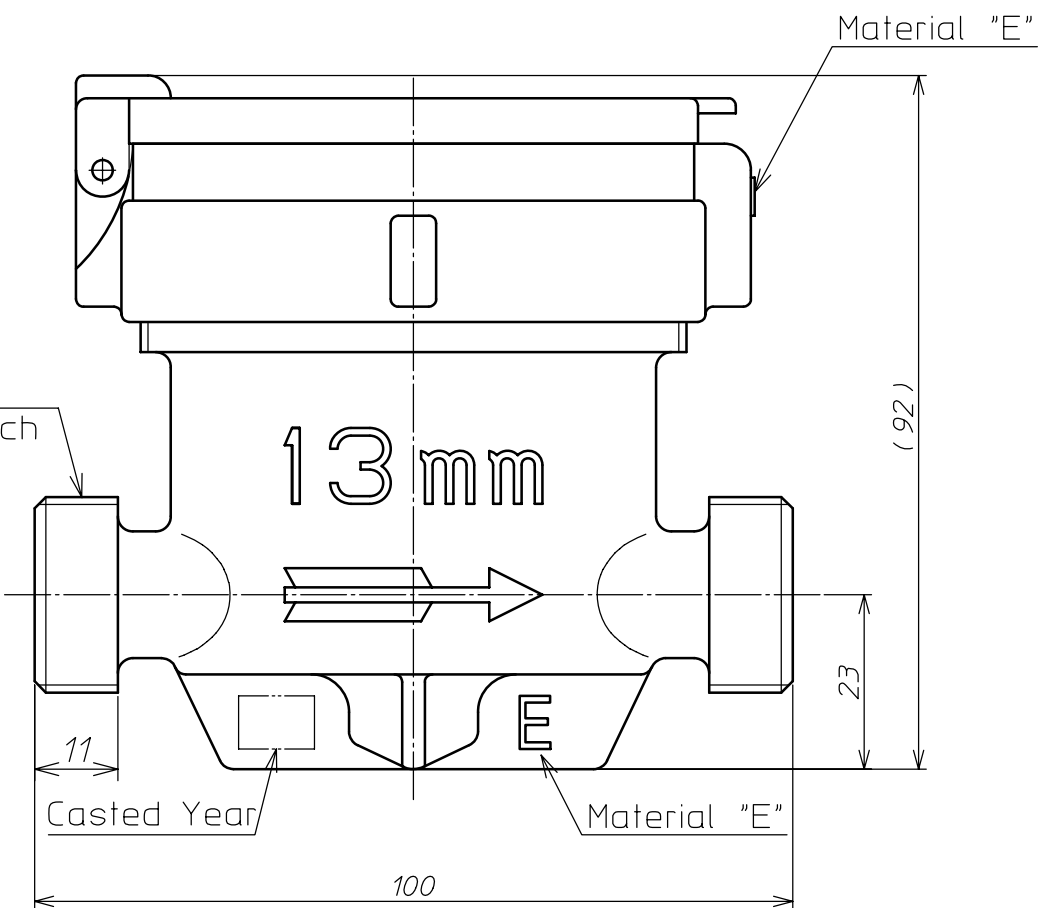

| | | | | | | | | | | | | | | | | | | |
|---|-----------|-----------|-------------|----------------|-------|------------------------|--|---|--|--|--|---|--|--|--|----------|--|--------|
| <table border="1"> <tr> <td>3</td> <td></td> <td></td> <td></td> </tr> <tr> <td>2</td> <td></td> <td></td> <td></td> </tr> <tr> <td>1</td> <td></td> <td></td> <td></td> </tr> </table> | | | | 3 | | | | 2 | | | | 1 | | | | MATERIAL | | REMARK |
| 3 | | | | | | | | | | | | | | | | | | |
| 2 | | | | | | | | | | | | | | | | | | |
| 1 | | | | | | | | | | | | | | | | | | |
| MARK | | | | PROJECTION | SCALE | NAME | | | | | | | | | | | | |
| COUNT | | | | | | FRONT VIEW | | | | | | | | | | | | |
| DATE | | | | Azbil Kimmon | | DRAWING No. | | | | | | | | | | | | |
| REVISION | | | | Co.,Ltd. JAPAN | | Y-NKDA013-A900B-000A00 | | | | | | | | | | | | |
| APPROVED | CHECKED | DRAWN | DATE | | | | | | | | | | | | | | | |
| H.Ogiu | K.Ohtsuka | K.Fukaumi | 1.Apr.,2012 | | | | | | | | | | | | | | | |

1

4